

## Bore Clamps Eccentric

### Pneumatic seat check and clamping monitoring

bore holes  $\varnothing$  8 – 12 mm, double acting, max. operating pressure 80 and 120 bar

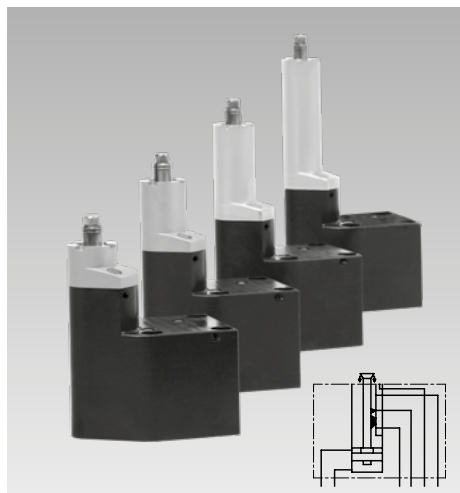

#### Application

The hydraulically-operated bore clamp is particularly suitable for clamping in workpieces with smooth bore holes in the support surface ranging from 8 to 12 mm in diameter.

The workpiece is placed directly onto the hardened supports of the bore clamp and is not deformed during clamping.

Since clamping is effected within the bore, the remaining surfaces are free for machining on 5 sides.

#### Description

The double-acting hydraulic cylinder operates a tie bolt that is eccentrically arranged at the edge of the housing in which the clamping bolt is safely engaged.

This conical clamping bolt expands the hardened clamping bushing so that its points penetrate the bore surface in the workpiece with a positive fit (see "Clamping principle").

Clamping bolt and clamping bushing can be exchanged very quickly after loosening the workpiece support. The bore clamp can remain on the fixture and no hydraulic oil escapes.

All functions can be monitored pneumatically.

The use of the connection for positive air pressure protection prevents liquids and swarf from entering the clamping bushing.

#### Important notes!

The bore clamp has no centring function. To insert and position the workpiece, suitable guides and centring bolts must be provided.

The centring bolts also have to absorb the occurring side loads during machining.

A distortion-free workpiece clamping is only guaranteed if the workpiece rests backlash-free on all bore clamps.

The specified clamping forces are only achieved if the points of the clamping bushing penetrate into the bore wall (see also "Clamping principle" and "Technical characteristics").

If swarf and liquids penetrate into an open clamping bore, positive air pressure must be continuously switched on.

Axial clamping in smooth bore holes

Machining from 5 sides

Reduced processing times

Higher precision by tools in standard length

Short tool paths

Clamping force up to 5 kN

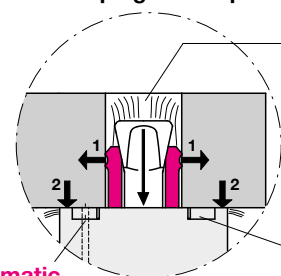

Positive air pressure protection  
Clamping bolt and clamping bushing easily exchangeable

Hardened workpiece support

Pneumatic seat check

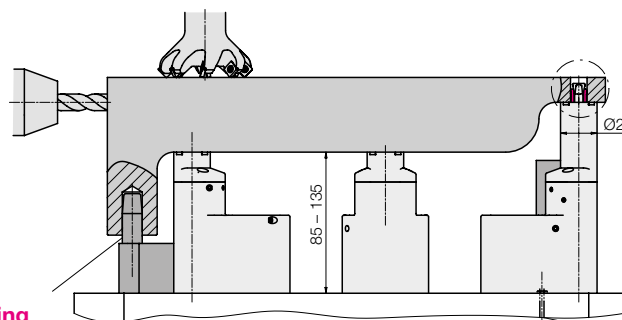

Different support heights

Eccentric design with small neck diameter

Positioning and side load absorption

2 x hydraulics  
4 x pneumatics

Smaller fixtures and machine tables

Corrosion-protected components

Efficient swarf management

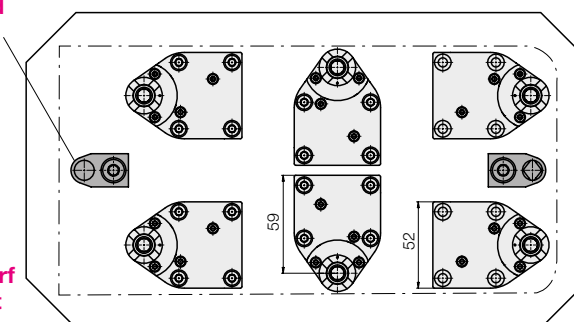

#### Function

After pressurising, the conical clamping bolt will be retracted. The clamping bushing will be expanded and the points penetrate into the bore hole wall.

With the penetration of the points increases the hydraulic pressure and thus the clamping force.

During unclamping, the clamping bolt extends again. The clamping bushing is relieved and pulled together by a ring spring.

#### Function control

With bore clamps, visual control of the clamping process is not possible because they are concealed by the workpiece.

For this eccentric bore clamp, three pneumatic and one hydraulic control options are available as standard:

- Seat check
- Clamping monitoring
- Unclamping monitoring
- Operating pressure control by external pressure switches

#### Functional safety

The functional safety is guaranteed if

- the workpiece material allows the clamping bushing to penetrate into the bore wall (see Technical characteristics);
- the diameter of the clamping bore is within the admissible tolerance range of the clamping bushing used;
- the clamping bore in the workpiece is round and perpendicular to the support surface;
- the workpiece rests on the entire surface perpendicular to the bore clamp;
- the support surfaces are free of dirt and swarf;
- the positive air pressure connection is switched on to blow away liquids and chips.

We recommend the use of all control options so that information about the current operating status is available at all times.

A detailed description with a function chart and the hydraulic and pneumatic circuit diagram can be found on page 4.

**Clamping principle**

To ensure that the workpiece is clamped onto the hardened workpiece support with the highest possible force, a positive connection must be established between the clamping bushing and the smooth bore wall.

During the clamping process, the conical clamping bolt spreads the hardened clamping bushing and the circumferential points penetrate into the softer workpiece material.

The penetration depth depends on the hardness of the material. Hardened, highly-tempered but also too soft materials are therefore not suitable (see "Technical characteristics").

In case of doubt, a clamping test should be carried out.

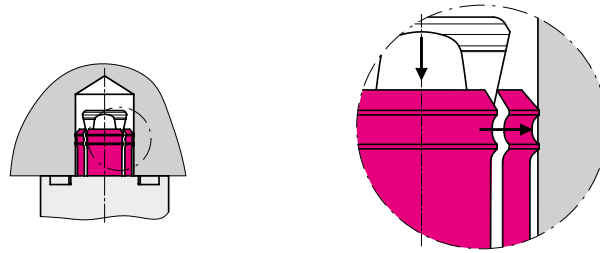

**Clamping bore**

A closed clamping bore has the advantage that no swarf or liquids can get into the bore clamp through the clamping bushing during machining.

However, the positive air pressure connection can only be switched off if no liquid is present at the workpiece support.

With the open bore, however, the positive air pressure connection must remain permanently switched on.

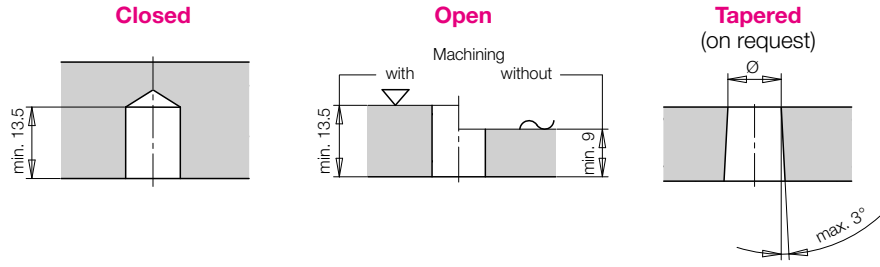

**Clamping bushings**

Example: clamping bore Ø 10 mm

**Nominal diameter of the clamping bushing 10**

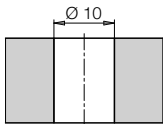

**Clamping bushing unclamped**

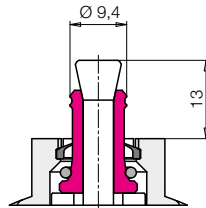

**Admissible tolerance of the clamping bore**

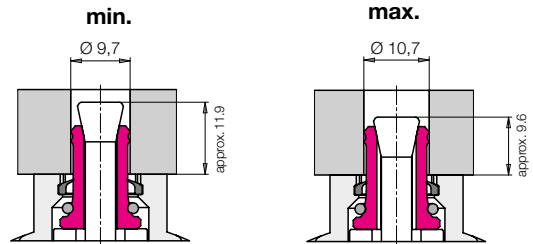

**Workpiece loading and positioning**

The workpiece is to be guided by insertion pins, especially during automatic loading by robots. The bore clamps have no centring function. Additional positioning pins (round and flattened) have the following functions:

- to bring workpieces into an exact machining position;
- to absorb side loads if these are greater than 10 % of the clamping force of the bore clamps.

The functions "Insert" and "Position" can be combined if the centring is long enough (see example a > b).

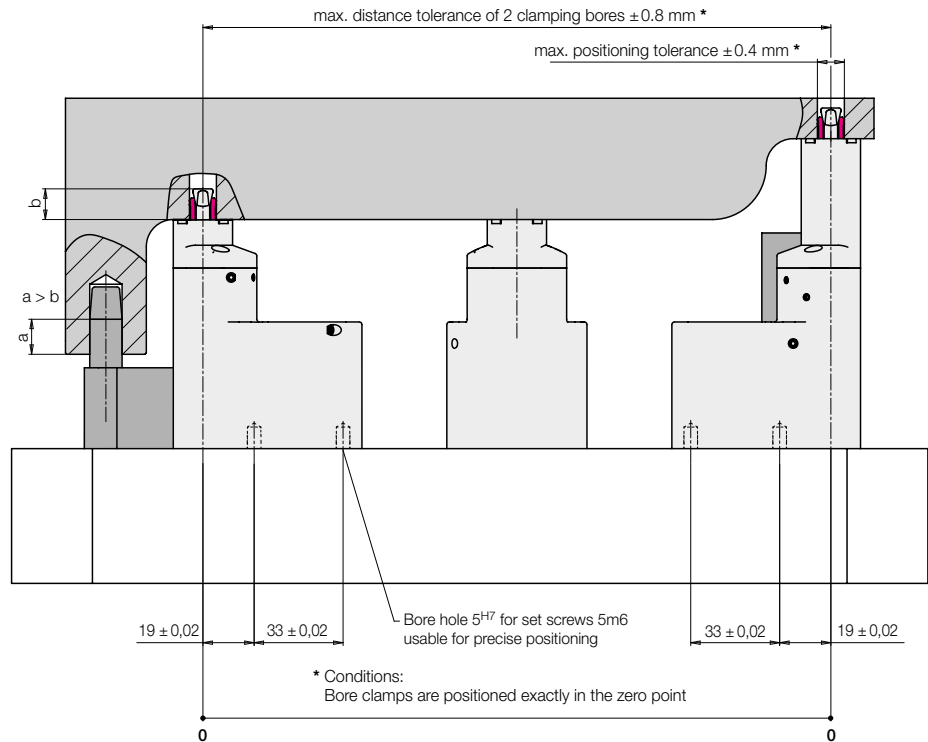

**Positioning tolerance**

Since the clamping bushing in the housing is radially movable, the workpiece can be positioned with a positioning tolerance of ± 0.4 mm.

**Distance tolerance**

The distance tolerance of 2 clamping bores can be max. ±0.8 mm if both bore clamps are positioned at the zero point (nominal dimension). This is made possible by using the two holes 5 H<sup>7</sup> in the flange surface of the bore clamps.

# Dimensions Technical Characteristics • Accessories

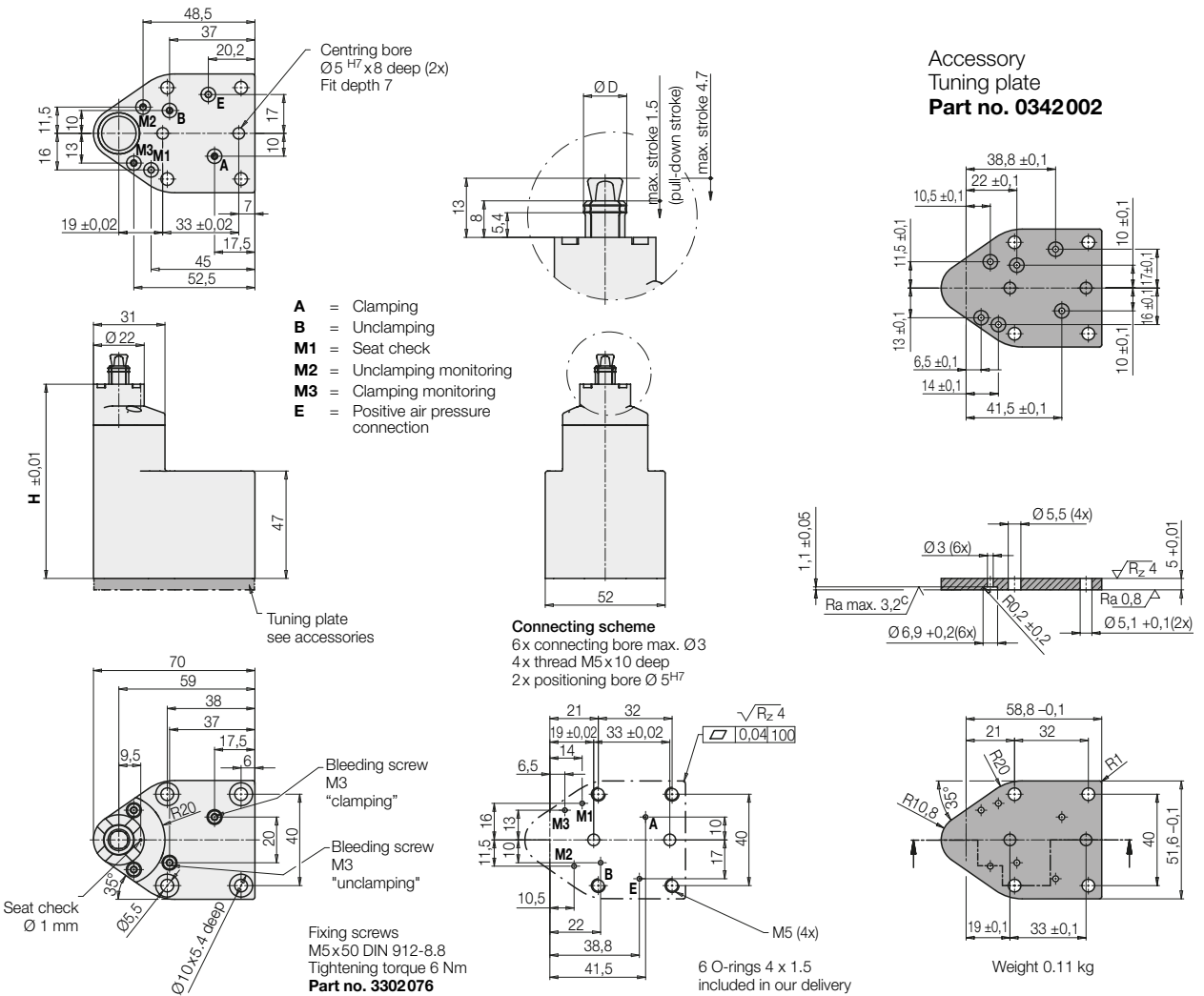

		8	9	10	11	12
<b>Bore hole Ø</b>	[mm]	8	9	10	11	12
Usable clamping range Ø	[mm]	7.7...8.7	8.7...9.7	9.7...10.7	10.7...11.7	11.7...12.7
<b>Max. clamping force</b> +10 ... -15 %	[kN]	3.3	3.3	5	5	5
Max. radial expansion force approx.	[kN]	8	8	14	14	14
<b>Max. operating pressure</b>	[bar]	80	80	120	120	120
Min. operating pressure	[bar]	20	20	20	20	20
Workpiece material	max. hardness HB/HRc			250/25		
	max. tensile strength			850		
Required positioning tolerance (see page 2)	[mm]			+/- 0.4		
Max. out-of-roundness of the workpiece bore	[mm]			0.1		
Clamping bolt stroke	[mm]			4.7		
Clamping bushing stroke (pull-down clamping)	[mm]			max. 1.5		
Oil volume clamping/unclamping	[cm³]			4 / 3		
Adm. flow rate	[cm³/s]			25		
Hydraulic oil as per DIN 51524-2				HLP 32		
Temperature range	[°C]			0...80		
Recommended sensor air pressure (see page 4)	[bar]			2...4		
Recommended pressure for positive air pressure connection with / without function control	[bar]			max. 1 / 3		

### Clamping force diagram

— = Nominal value  
 = Tolerance range

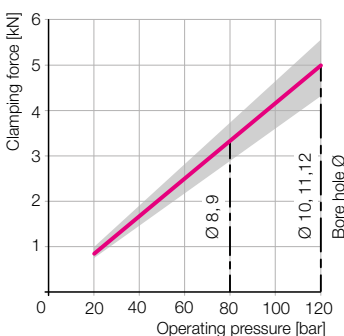

### Elastic deformation ΔH when clamping the workpiece

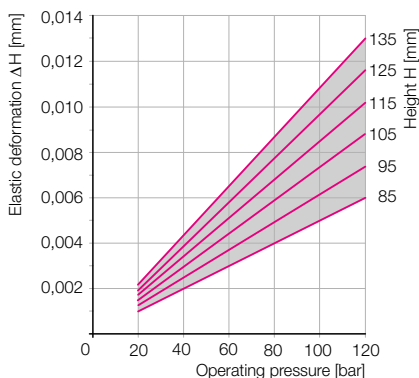

### Part no. BCE1XX0 HXXXSZ

Bore hole Ø [mm]	Height H [mm]	Elastic deformation ΔH with load [µm / kN]	Weight [kg]
<b>BCE1XX0</b>	<b>HXXXSZ</b>		
08	085	-1.60	1.20
09	095	-1.88	1.22
10	105	-2.16	1.24
11	115	-2.44	1.26
12	125	-2.72	1.28
	135	-3.00	1.30

Other sizes on request.

## Pneumatic function controls

The bore clamp clamps the workpiece within smooth bores located in the support surface. A visual control of the clamping process is therefore impossible.

Three pneumatic function checks are available for this purpose:

- **Seat check M1**

Signals the backlash-free contact of the workpiece on the hardened support and is therefore a prerequisite for initiating the clamping process.

- **Unclamping monitoring M2**

Signals the unclamping position of the clamping bolt and thus the opening of the clamping bushing.

Together with pressure switch P2, this is a prerequisite for unhindered loading and unloading of the workpiece.

- **Clamping monitoring M3**

Signals that the clamping bolt is in the optimum clamping range and that the clamping bushing fits the diameter of the clamping bore.

Together with the seat check M1 and the pressure switch P1, the signal serves for processing release.

## Hydraulic function controls

- **Clamping pressure P1**

Signals that the set operating pressure and the desired clamping force are applied. Together with the seat check M1 and the clamping monitoring M3, the signal serves for processing release.

- **Unclamping pressure P2**

Signals that the tie rod is held in unclamping position by hydraulic pressure. Together with the unclamping monitoring M2 this is the release for the workpiece change.

## Error message in clamping state

(see chart "Examples for ...")

Possible sources of error are

- clamping bore too large
- clamping bore out of tolerance
- clamping bore tapered or non-circular
- workpiece material too hard
- workpiece material too soft
- clamping bushing worn or defective
- clamping bolt defective

## Signal conversion Pneumatics → Electrics

If a pneumatic bore is closed, the air pressure in the measuring system increases.

An electro-pneumatic measuring device can either measure the pressure increase or a drop of the air flow rate and convert it into an electrical signal.

### Pneumatic pressure switch

Advantage: easy adjustment

To achieve a sufficient hysteresis of 1–2 bar, the air flow rate must be limited to approx. 12 l/min with a flow control valve. This adjustment is made with an additional flow sensor with digital flow rate display.

### Differential pressure switch

Differential pressure switches (e.g. PEL System) require only 0.5 to 1.5 bar working pressure. The exact adjustment of a setting nozzle under practical conditions is required.

### Flow sensor

A function control is also possible independent of pressure by measuring the flow rate. The flow sensor should have a digital display and one adjustable limit switch with a binary output (such as type SFAB of Festo).

## Hydraulic and pneumatic circuit diagram with all function checks and positive air pressure connection.

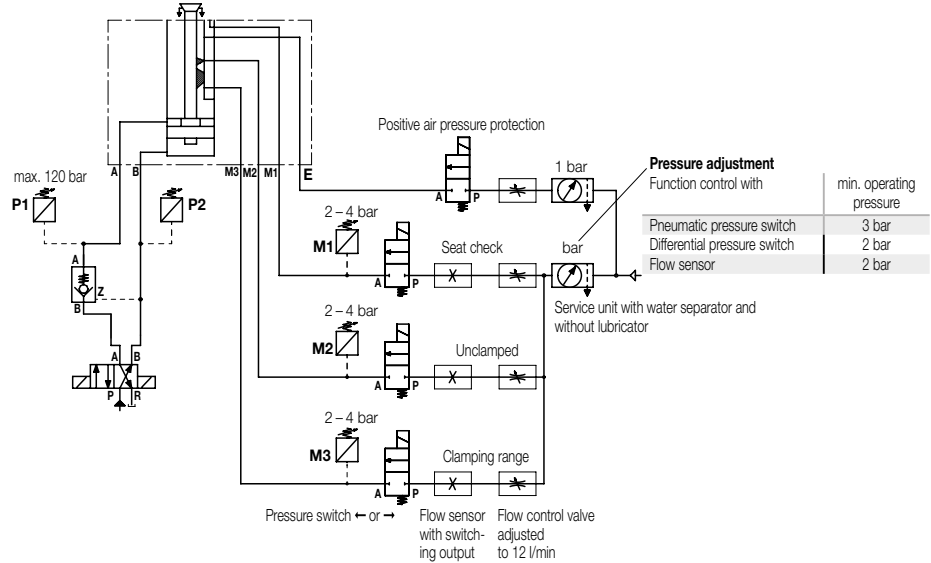

## Function chart

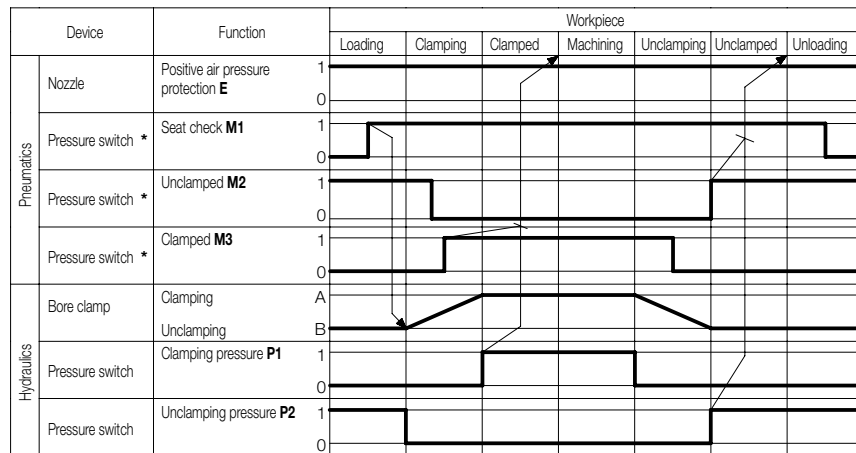

\* alternatively differential pressure switch or flow sensor

## Examples for switching positions when using all control elements

Control elements	Status of control elements	Bore clamp		
		Unclamped and workpiece does not lie flat on the surface	Clamped Processing release	Error message in clamped state
Seat check <b>M1</b>	0	1	1	
Unclamping monitoring <b>M2</b>	1	0	0	
Clamping monitoring <b>M3</b>	0	1	0	
Clamping pressure <b>P1</b>	0	1	1	
Unclamping pressure <b>P2</b>	1	0	0	

← **Error!**  
(see text)

## Example

Six seat checks with 2 bar air pressure:

1. Cover all seat checks with one workpiece and measure the flow rate  $Q_{min}$ .
2. If one seat check is not covered, measure  $Q_{max}$ .
3. Enter and save switching threshold =  $0.5 \times (Q_{max} + Q_{min})$ .

If the difference ( $Q_{max} - Q_{min}$ ) is too small, increase the flow rate or reduce the number of bore clamps per sensor.

## Number of bore clamps at a function control

For the monitoring of a function, e.g. the seat check, a group of max. 6 bore clamps can be connected to one measuring device.

The calibration of the switching pressure requires great care, because the measuring device has to recognize that, for example, only one of the 6 seat checks is not covered. It is not possible to see which one that is!